

Electr. Dual Temperature Switch

BTS3000

Features

- ▶ Measuring ranges: 0 ...100 °C to -30 ... 140 °C
- ▶ max. 2 switch points
- ▶ Analogue output 4 - 20 mA or 0 - 10 V
- ▶ Rotatable 320° display & electrical connection
- ▶ Menu navigation refers to VDMA standard
- ▶ IO-Link communication interface

Applications

- ▶ Temperature control for
 - Hydraulics & Pneumatics
 - Lubrication systems
 - Cooling



Technical Data

Sensor element:	PT100 Class A DIN/IEC 60751
Materials:	
Wetted parts:	Stainless steel
Electronics housing:	Stainless steel, PBT, PA6.6 GF30
Seals:	FKM, EPDM
Operating elements:	3 easy-response pushbuttons
System of protection:	IP65, IP67
Protection class:	III
Electrical connection:	Plug M12 x 1, 4-pin / 5-pin / 8-pin (depending on output code)
Process connection:	see order code
Dimensions:	110 x 41 mm (without plug connector and probe)
Weight:	approx. 200 g
A/D converter:	
Resolution:	12 bit (4096 steps per measuring span)
Scanning rate:	1000 / s
Linearity error:	< ± 0.5 % v. f. s. at +25 °C
Temperature influence:	< ± 0.2 % FSO / 10K
Compensation range:	-10 °C... +70 °C
Repeatability:	± 0.1 % v. f. s
Time constant T_{0.9} :	40 sec
Max. pressure:	200 bar
Temperature range:	
Electronics:	-10 °C... +60 °C
Storage:	-30 °C... +80 °C
Power supply:	15... 28 V DC, output code 6: 20... 28 V DC reversed polarity protected (SELV, PELV)
Digital display:	4-digit 14-segment LED display, red, digit height 9 mm
Error display:	LED red and alphanumeric display
Power consumption:	approx. 50 mA (without load) output code 6: approx. 80 mA
Relay output:	Rel. 1 normally closed, Rel. 2 normally open Load: max. 1A, max 60 V, max. 30 W
Analog output:	
Current output:	4...20 mA
Load:	max. RI = (Ub-12V) / 20 mA RI = 600 Ohm at Ub = 24 V DC
Scanning rate:	2 ms
Voltage output:	0...10 V DC
Rating:	max. 10 mA
Adjustment range:	25 %... 100 % f. s.

Transistor switching outputs / IO-Link:		
Switching function:	Normally open/normally closed, standard / window mode and diagnosis function adjustable	
Adjustment range for switching point and hysteresis:	0 %... 125 % f. s.	
Switching frequency:	max. 100 Hz	
Load:	max. 500 mA, short-circuit proof, IO-Link: max. 250 mA	
Delay:	0.0 s ... 50 s adjustable	
Status display(s):	LED(s) red	
Interfaces:		
Communication interface:	IO-Link	
Transmission type:	COM2 (38,4 kBaud)	
IO-Link revision:	1.1	
SDCI standard:	IEC 61131-9	
Profiles:	Smart Sensor	
SIO mode:	yes	
Device type:	Class A	
Process data variable:	1	
Binary data channel:	2	
Min. process cycle time [ms]	2.5	
Device ID:	0x031...	
EMV / ESD	EN 61000-4-2 ESD	4 kV CD / 8 kV AD
	EN 61000-4-3 HF radiated	10 V/m
	EN 61000-4-4 Burst	2 kV
	EN 61000-4-5-Surge	1/2 kV
	EN 61000-4-6 HF conducted	10 V
Shock resistance:	DIN EN 60028-2-27	50 g (11 ms)
Vibrations resistance:*	DIN EN 60028-2-26	20 g (10...2000 Hz)
Approvals:	cULus ¹⁾ - E302981	

¹⁾ not for option output Code 6

Techniquip Ltd
The Old Brewery
Norton Fitzwarren
Taunton
TA2 6RN
Tel 01823-351255
eMail sales@techniquip.co.uk
www.techniquip.co.uk



Electr. Dual Temperature Switch

BTS3000

Accessories

Order Number	Description
907-0357	Plug connector M12 x 1, 4-pin, with screw terminals, angled (IP65)
907-0185	Plug connector M12 x 1, 5-pin, with screw terminals, angled (IP65)
908-0361	Plug connector M12 x 1, 5-pin, with moulded cable (IP67), 2 m length
908-0544	Plug connector M12 x 1, 8-pin, with moulded cable (IP67), 2 m length

Dimensions (mm / inch)

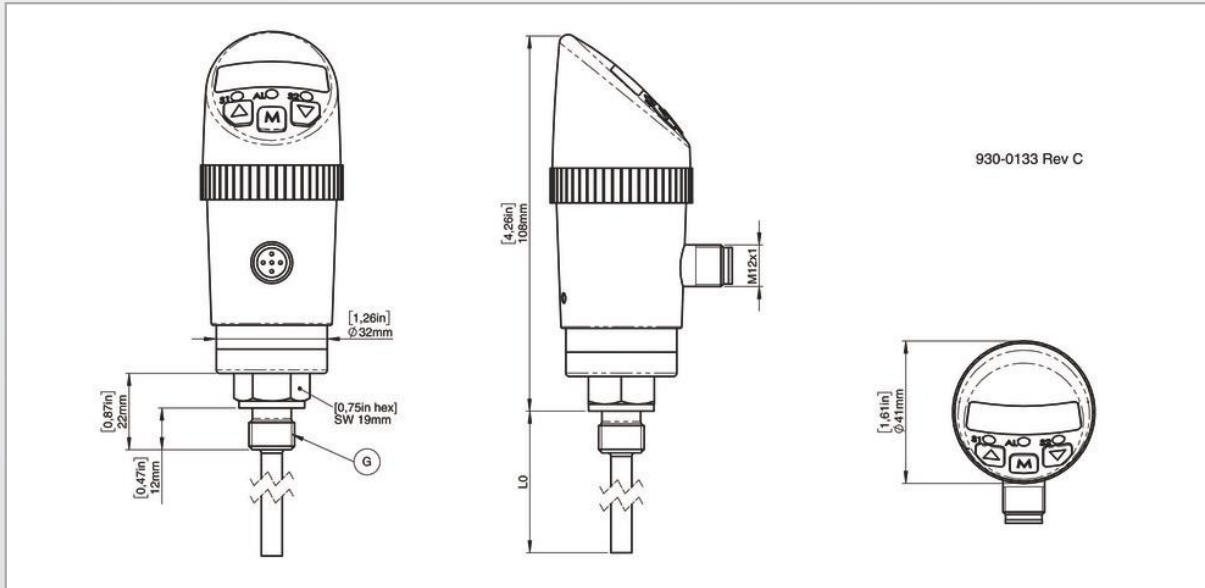

Process connection

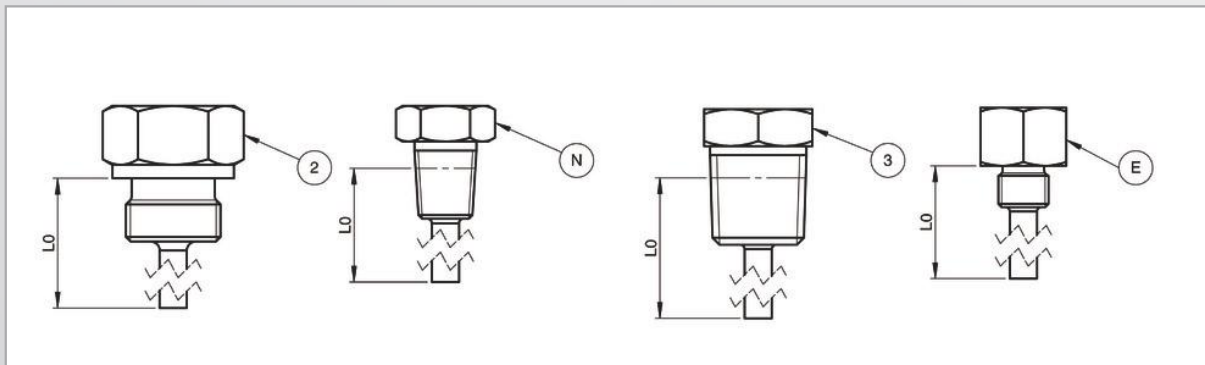

Legend

G	G1/4"
2	G1/2"
N	1/4" NPT
3	1/2" NPT
E	7/16-20 UNF (SAE)

Plug

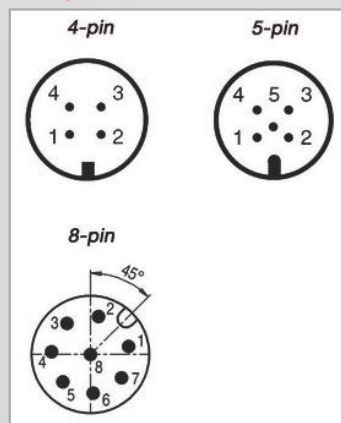

Electrical Connection

Pin	Signal Output Code 1, 7	Signal Order Code 2, 3	Signal Output Code 4, 5, 8	Signal Order Code 6
1	+Ub	+Ub	+Ub	+Ub
2	SP2	Signal	Signal	SP1a
3	0V	0V	0V	SP1b
4	SP1 / IO-Link*	SP1	SP1 / IO-Link*	0V
5	-	-	SP2	SP2a
6	-	-	-	SP2b
7	-	-	-	-
8	-	-	-	Housing

* only code 7 and 8

Order Code

BTS3000

BTS3	Base Mode
Output	
1	2 switch points
2	4...20 mA - 1 switch point
3	0...10 V 1 - switch point
4	4...20 mA - 2 switch points
5	0...10 V 2 - switch points
6	2 relais switch points (1x NO SPST / 1 x NC SPST)
7	IO-Link / 2 switch points (PNP, NPN, PP)
8	IO-Link / 2 switch points (PNP, NPN, PP) / Analog Output

Process Connection	
G	G1/4" ext. thread Sealing Code V, E and F
2	G1/2" ext. thread (Sealing Code V, E and F)
N	1/4" NPT ext. thread (Sealing Code X)
3	1/2" NPT ext. thread (Sealing Code X)
E	7/16...20 UNF ext. thread (Sealing Code V, E, and F)

Sealing	
V	FKM
E	EPDM
F	FFKM on request
X	No Sealing other on request

Electrical Connection	
M	M12
Probe length*	
0 0 1 7 M	17 mm (Process Connection Code G and 2)
0 0 2 5 M	25 mm (Process Connection Code G and 2)
0 0 5 0 M	50 mm (Process Connection Code G and 2)
0 1 0 0 M	100 mm (Process Connection Code G and 2)
0 3 0 0 M	300 mm (Process Connection Code G and 2)
0 6 5 0 M	650 mm (Process Connection Code G and 2)
0 . 7 0 Z	0,7 in (Process Connection Code N, 3 and E)
2 . 0 0 Z	2 in (Process Connection Code N, 3 and E)
4 . 0 0 Z	4 in (Process Connection Code N, 3 and E)
6 . 0 0 Z	6 in (Process Connection Code N, 3 and E)
1 2 . 0 Z	12 in (Process Connection Code N, 3 and E)
	other on request

Temperature Range	
1	0 ... 100°C
2	-30 ... 140°C
3	32 ... 210°F
4	-22 ... 280°F

BTS3 3 G V M 0 0 1 7 M 2

* If probe length >100 mm shock and vibration values can deviate - depending on application.
 If probe length >300 mm kepp away the flow from the probe.
 If probe length < 25 mm linearity error and time constante values can deviate - depending on application.