



Firesure Duo - Groove Flowmeter



LPCB & FM APPROVALS FOR SPRINKLER FIRE PUMP TESTING



Single combined l/min and USGPM tube.

- Suitable for LPC and FM installations.
- Stable easy to read flow indication.

Isolation valves at inlet & outlet to indicator.

- Provides a permanent, safe and secure installation.
- Allows isolation from main pipe eliminating shocks at pump start up.
- Air is automatically vented when valves are opened.

Horizontal, inclined & vertical grooved connection.

- Flexibility in design & site positioning.
- Compact and simple installation.



Pipe OD mm	Nominal		Meter Code	Flow Test Ranges		Pump duty USGPM	LPC App Ref	FM App Ref FS
	mm	/ inches		LPCB l/min	FM USGPM			
60.3	50	2	L G100	150-700	n/a	100	464a/06	-----
88.9	80	3	DUO G200	300-1600	100-400	150,200	464a/07	80FGFM
114.3	100	4	DUO G450	500-3500	150-900	250;300;450	464a/08	100FGFM
165.1	150	6	DUO G1000	900-7900	250-2000	500;750;1000	464a/09	150FGFM
168.3	150	6	DUO 6 G1000	900-7900	250-2000	500;750;1000	464a/22	6-FGFM
219.1	200	8	DUO G2000	2000-15000	750-4000	1250;1500;2000	464a/10	200FGFM
219.1	200	8	F8 G3000	n/a	1500-6000	2500;3000	-----	8-FGFM

Mounting Detail – Firesure Duo-Groove Flowmeter:

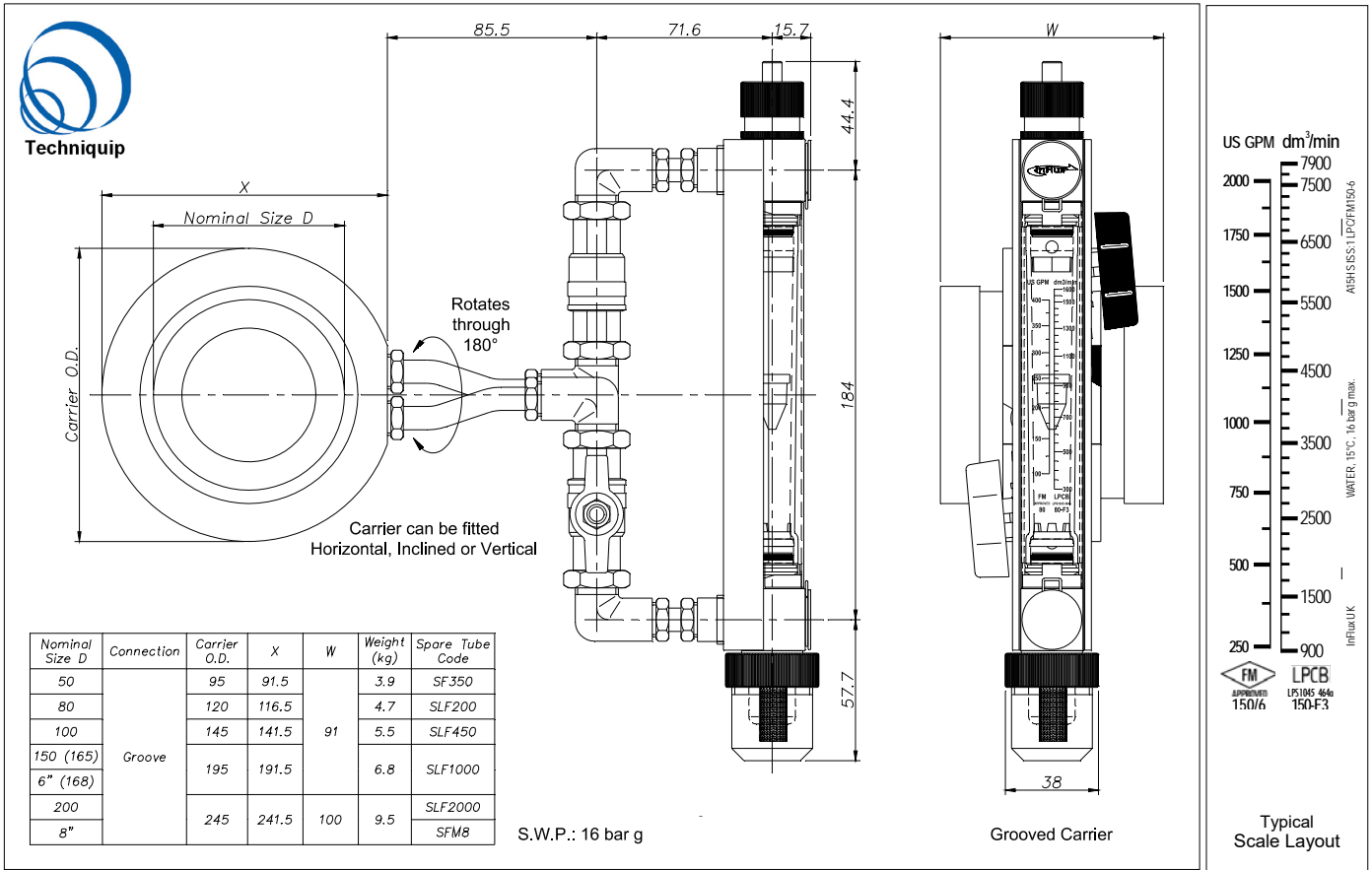

Typical Pipeline Configuration (Horizontal or Vertical):

