

Bourdon Tube Press. Switches

B1X/B2X

Mechanical single/dual pressure switch
Repeatability ± 1.0 % at constant temperature

Features

Bourdon tube pressure switch
All welded parts wetted.
Direct acting, no friction, high accuracy

Adjustment ranges

5.3 ... 496 bar

Applications

Petrochemicals industry,
Process technology,
Shipbuilding technology,
Alarm applications

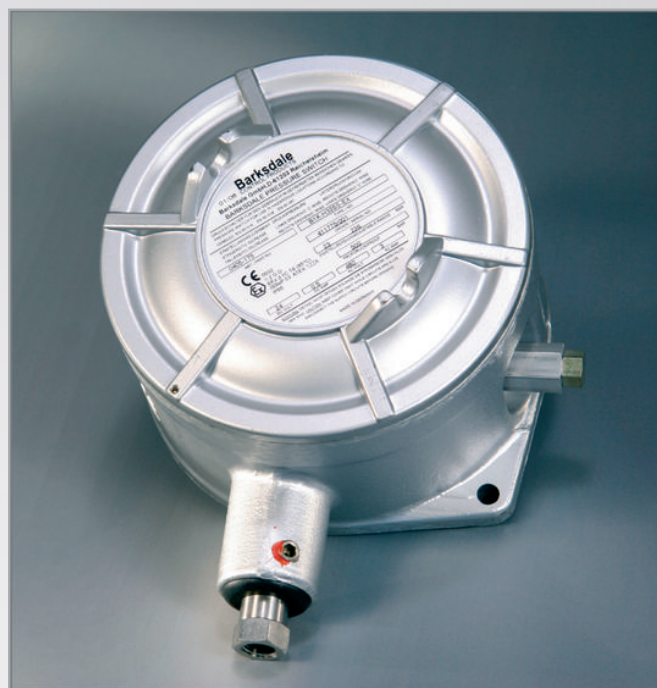

Technical Data

Wetted parts:	
Process connection:	Stainless steel 1.4401
Bourdon tube:	Stainless steel 1.4401
Repeatability:	± 1 % at constant temperature
Switching rate:	max. 20/min
Temperature range:	-40 °C... +75 °C
Protection class:	IP65
Housing:	Explosion proof housing, aluminum anodized and lacquered
Process connection:	1/4" NPT female thread except ranges marked with*). These switches have proof pressures above 500 bar and are provided with high pressure thread with adapter G1/4" IG.
Electrical connection:	Internal terminal strip (0.5 - 2.5 mm ²), approved cable gland has to be provided by the customer
Electrical rating and hysteresis:	Many micro switch versions with different switching powers and hysteresis are applicable and make it possible to make customized changes.

Weight:	B1X-....: approx. 3.9 kg B2X-....: approx. 3.9 kg
Set point adjustment:	Turn the adjustment screw clockwise to decrease the set point.
Intrinsically safe:	The switches are designed for intrinsically safe applications. Please add "Exi" to your ordering details when placing an order. To comply with the intrinsically safe approval following max. ratings must not be exceeded: U _{max} = 28 V I _{max} = 50 mA
Approval:	Ex: Ex d II C T6 acc. to ATEX cULus: Class I, Groups B, C, D Class II, Groups E, F, G acc. to Underwriter Laboratories Inc. and Canadian Standard Assn.

Pressure Ranges

Pressure range code	Adjustment range [bar]		Max. operating pressure [bar]	Proof pressure [bar] (short term)	Max. hyst. of the different switches in bar (end of range)	
	Increasing press.	Decreasing press.			H, GH [bar]	M, GM [bar]
12SS	5.3... 83	3.4... 81	100	125	0.96	1.86
20SS	13.7... 137	11.0... 134	250	330	2.68	5.44
32SS	22.4... 220	16.5... 215	400	500	2.75	5.90
72SS*	79.3... 496	41.4... 459	600	950	16.90	37.90

Bourdon Tube Press. Switches

B1X/B2X

Dimensions (mm / inch)

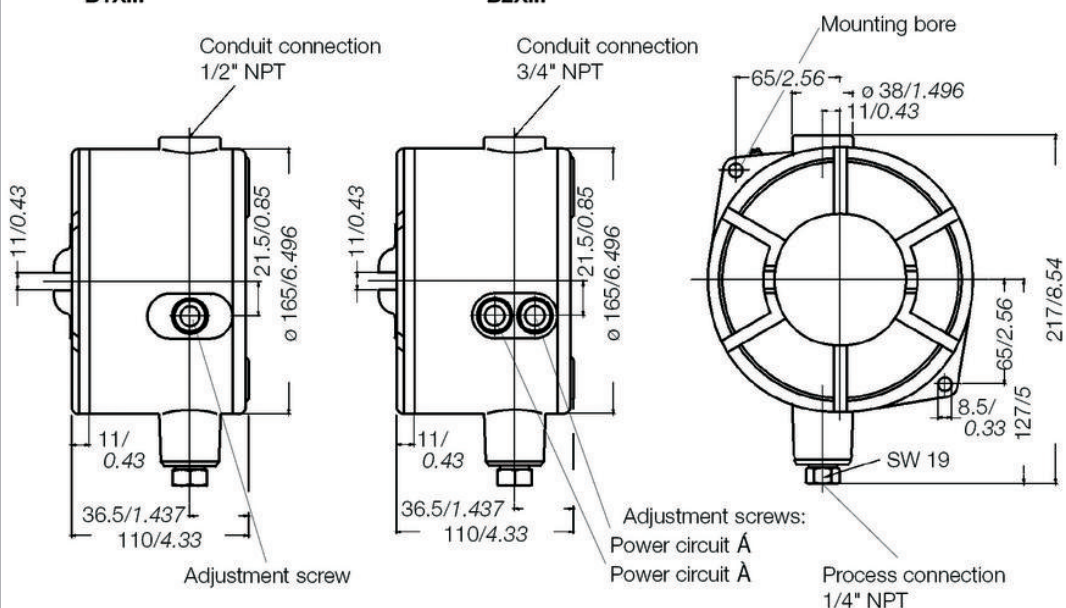

B1X...

B2X...

Conduit connection 1/2" NPT

Conduit connection 3/4" NPT

Mounting bore

65/2.56

38/1.496

11/0.43

11/0.43

21.5/0.85

165/6.496

11/0.43

36.5/1.437

110/4.33

Adjustment screw

Adjustment screws:
Power circuit A
Power circuit A

Process connection 1/4" NPT

SW 19

65/2.56

217/8.54

8.5/0.33

127/5

Switching- and connection diagram for all types (pressureless)

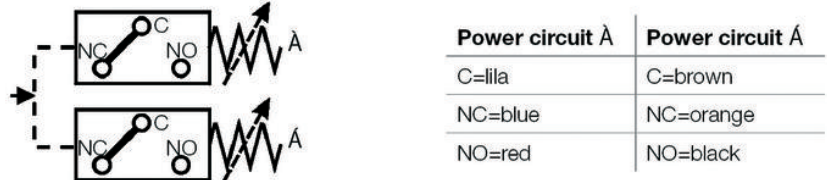

Power circuit A	Power circuit A
C=lila	C=brown
NC=blue	NC=orange
NO=red	NO=black

Electrical Ratings

Micro switch	Special features	Volt AC 50/60 Hz	Ind. load A	Res. load A	Volt DC	Ind. load A	Res. load A	Comments
H	Micro switch with silver contacts	125 250 480*	10 10 3	10 10 3	6 to 24	0.50	0.5	Small hysteresis; High AC-/ low DC-load
M	Micro switch with silver contacts	125 250 480*	10 10 3	10 10 3	12 24 250*	5.00 1.00 0.25	15.0 2.0 0.4	Medium hysteresis; High AC- and DC-loads
GH	Micro switch with gold-plated contacts for low voltage and/ or low current	125	1	1	24	1.00	1.00	Small hysteresis
GM		30	0.1	0.1	30	0.10	0.1	Medium hysteresis

* on request

Approvals

EX	Ex d approval
UL	cULus approval
EXI	Ex i approval

Options

P2 = 1/2" NPT F SS Process connection

Order Code

Example for order number

Type	Micro switch	Pressure range code	Options	Approval
B1X or B2X	H	72SS	P2	UL

Your order number

Type	Micro switch	Pressure range code	Options	Approval